



HORIZONTAL LATHES

HLM

10.11.2019

STANDARD FEATURES

- Easy, manual control
- Bed width 558 mm up to 1150 mm
- Swing over bed up to 2000 mm
- Fast delivery times
- Wide range of accessories
- Easy maintenance



STANDARD TECHNICAL DATA



Horizontal lathes HLM (manual control)

- **Swing diameter 860 mm to 2000 mm**
- **Turning length 2 to 12 meter**

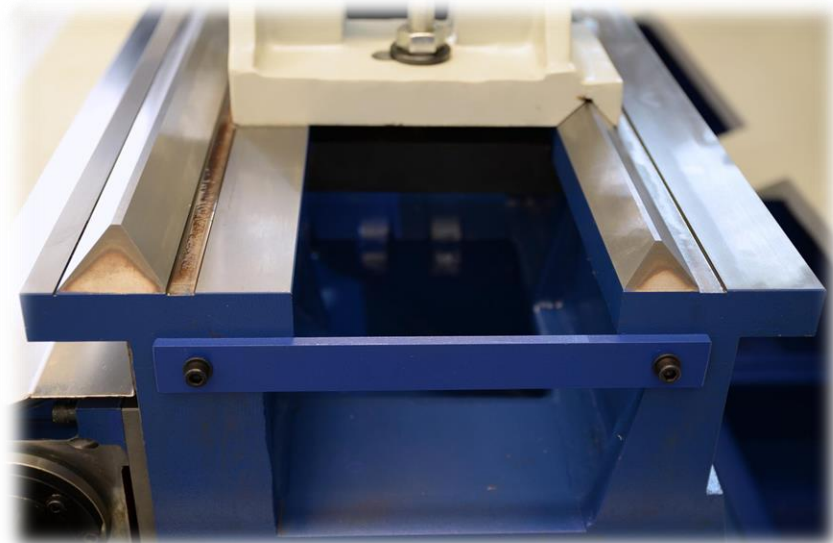



TURN

TYPE VERSIONS ACCORDING TO BED WIDTH



Bed width designed according to work type needs

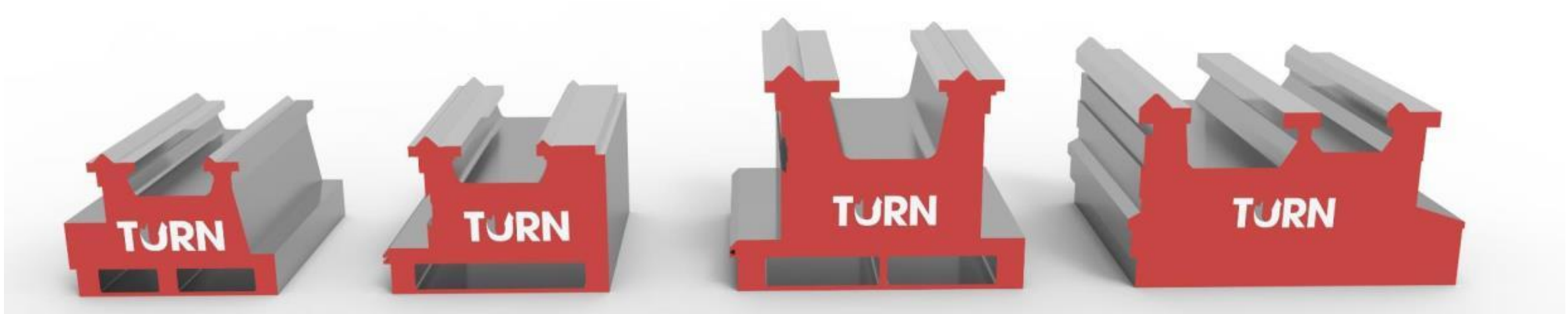

558 mm

692 mm

888 mm

1150 mm



STANDARD FEATURES

- Cast steel bed, hardened sliding guideways
- Twelve-step manual gearbox
- Cast iron tailstock, fixed quill
- Rapid traverse axes X and Z
- Machine covers
- Tool head H4, chip tray, center MK6
- Metric and imperial threading, Thread dial
- Electromagnetic spindle brake

OPTIONAL FEATURES

- Spindle bore up to 410 mm
- Digital readout FAGOR
- Quick-change tool head
- Modern machine covers
- Chip conveyor
- Three-step gearbox with pneumatic shifting and variable spindle speed

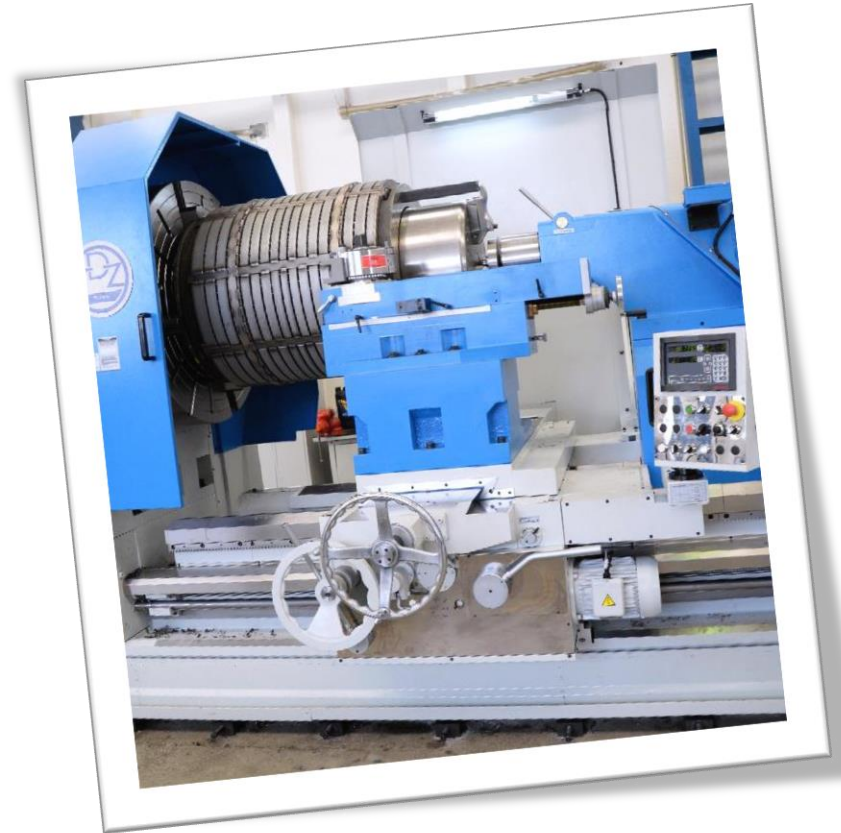

ACCESSORIES

- Rests,
- Boring bar holder,
- Tailstock quill pressure gauge,
- Rear chuck, tailstock chuck,
- Spindle speed indicator,
- Taper attachment...



SPINDLE

- Optional spindle bore 130 mm to 410 mm
- TIMKEN bearings class P5
- Interface according to ISO 702-1 (A2-11 až A2-28)

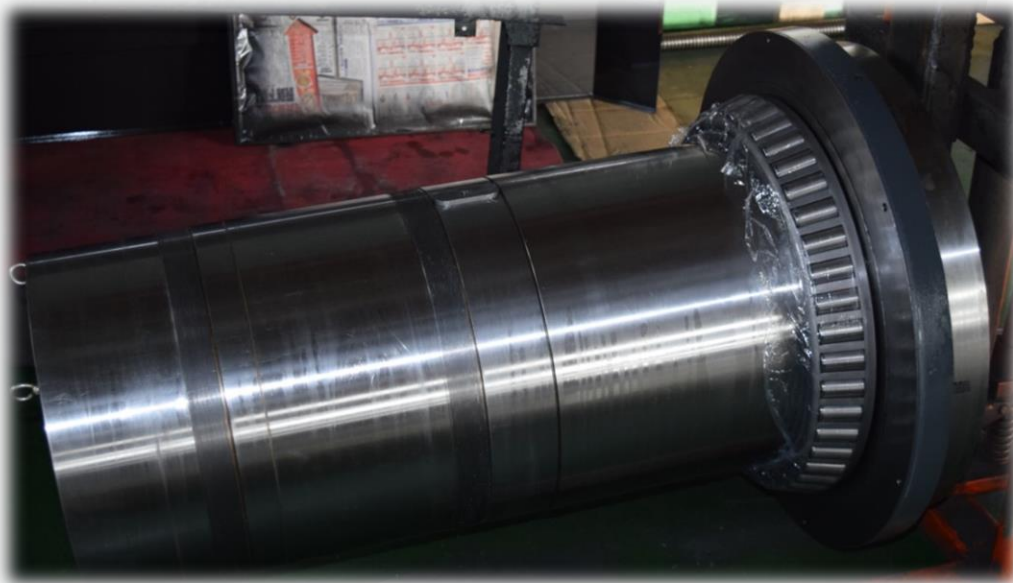

TURN

COMMON MACHINED PARTS



CLASSIC LATHE OF 21st CENTURY

- Modern covers, easy operation, digital readout, variable spindle speed

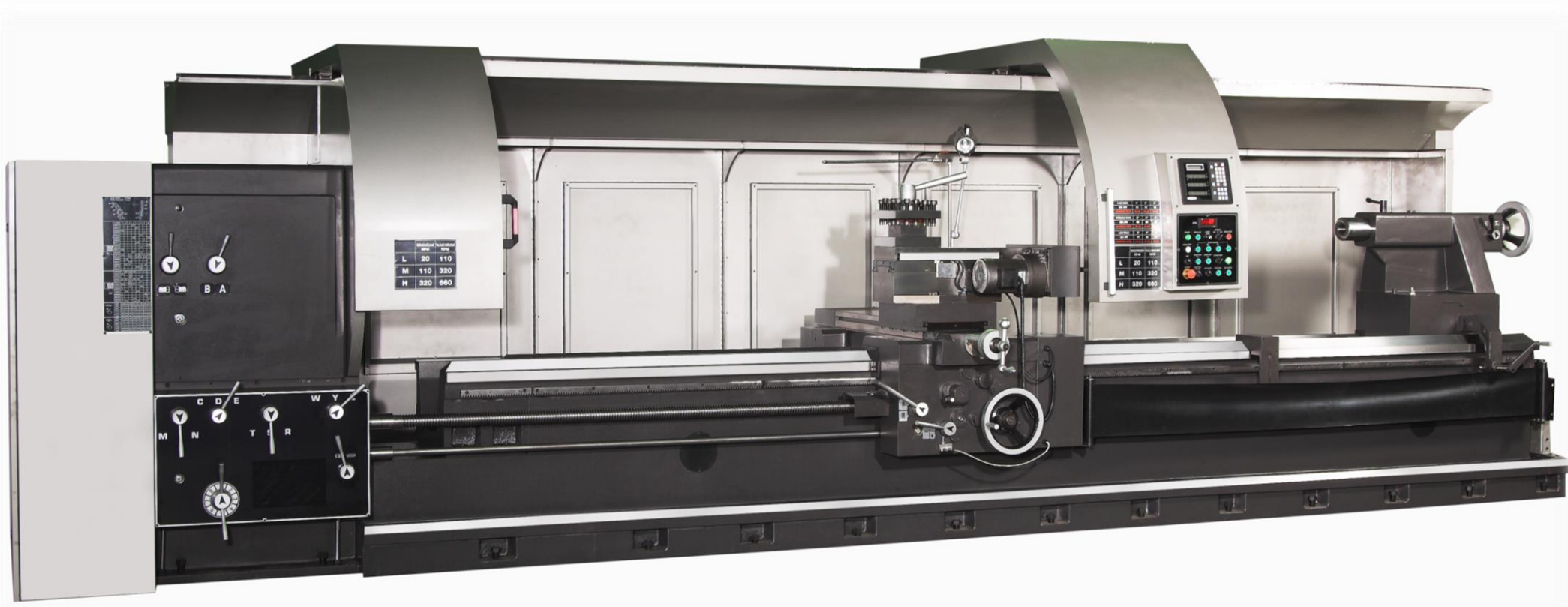

TDZ Turn s.r.o.

Táborská 4297/197

615 00 Brno

Česká republika

www.tdz-turn.com

info@tdz-turn.com



Distributed by:

CanAmera Machine Tools Inc.

Cambridge, ON

(519) 621-7819

info@canameramt.com

www.CanAmeraMachineTools.com